

LINCOLN 1990-93 MARK VII LSC

Coupe

TUNERS / CASSETTE / DISC PLAYERS						DISC EQ STACK
	MICRO	MINI	STAN	DIN 1	DIN 2	
CHASSIS H	1 ³ / ₄ -2	1 ³ / ₄ -2	2	2	2	4
CHASSIS W	6 ¹ / ₄	7 ¹ / ₈	7 ¹ / ₈	7 ¹ / ₈	7 ¹ / ₈	7 ¹ / ₈
CHASSIS D	5 ¹ / ₈	4 ³ / ₄ -5 ¹ / ₂	5 ⁷ / ₈ -6 ¹ / ₁₆	4 ³ / ₄ -5 ¹ / ₂	5 ⁷ / ₈ -6 ¹ / ₁₆	5 ⁷ / ₈ -6 ¹ / ₁₆
NOSE H	1 ¹ / ₂ -1 ⁹ / ₁₆	1 ⁵ / ₈ -1 ³ / ₄	1 ⁵ / ₈ -1 ³ / ₄	2 ³ / ₈	2 ³ / ₈	
NOSE W	3 ⁷ / ₁₆ -3 ¹ / ₂	4 ¹ / ₈ -4 ³ / ₁₆	4 ¹ / ₈ -4 ³ / ₁₆	7 ¹ / ₂	7 ¹ / ₂	
SHAFTSP.	4 ⁷ / ₈ -5 ¹ / ₈	5 ¹ / ₈ -5 ³ / ₄	5 ¹ / ₈ -6			

IN DASH APPLICATION NOTES

	K ⁵	K ⁵	K ⁵	P	P	N
--	----------------	----------------	----------------	---	---	---

IN-DASH INSTALLATION AREA DIMENSIONS

	DEPTH	WIDTH	HEIGHT	SHAFT CUP OFFSET
CAVITY	7 ³ / ₄ "	8"	2 ⁵ / ₈ "	LEFT
DASH OPENING		7 ¹ / ₈ "	2 ¹ / ₈ "	RIGHT
DASH MAT: PLASTIC		THICKNESS: 3 ³ / ₃₂ "		SHAFT SP.

AMPLIFIER LOCATIONS (WxHxD)

UNDER DASH	UNDER SEAT	REARSIDE PANEL	TRUNK
			VARIOUS

EQUALIZER LOCATIONS

DASH	CONSOLE	GL. BOX



UPDATED THROUGH
'92
'93
'94
'95

Dimensions shown are inches.
For inch/mm conversions refer to chart section.

Vehicle illustration courtesy of
NADA Used Car Guide.



CAVITY W H D
9¹/₂ x 9¹/₂ x 16"

FRONT DOORS

Factory Provisions: 5¹/₄" JBL with factory adaptor
Aftermarket: 4", 5", 5¹/₄", 6¹/₂", K

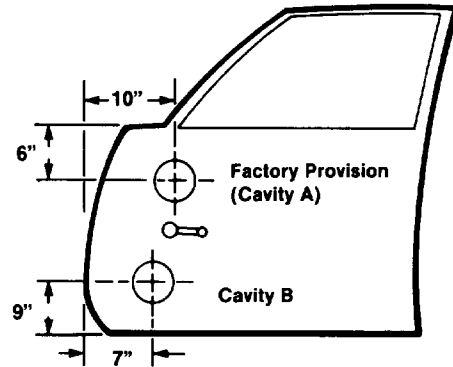

CAVITY W H D
A 9 x 6 x 2³/₄"

CAVITY W H D
B 6 x 6 x 2³/₄"

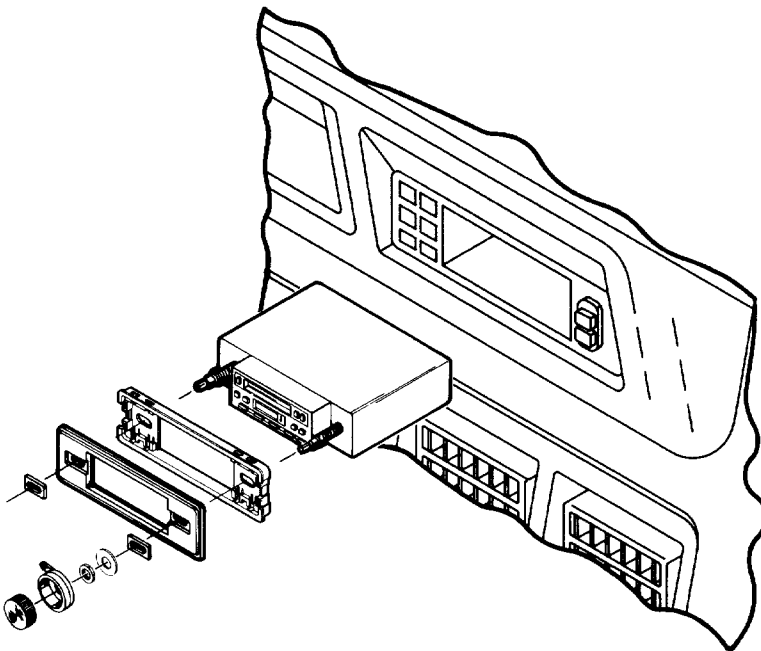

- B = BACK UP PLATES REQUIRED.
- C¹ = CUT TRIM/PLASTIC (STRUCTURE).
- C² = CUT STEEL.
- D = BELOW DECK ONLY.
- D¹ = LIFT PORTION OF DECK. (MAY REQUIRE STRUCTURAL REINFORCEMENT).
- D² = CUT STEEL WHEN TOP MOUNTED. DO NOT IF BELOW DECK.
- D³ = NARROW SURFACE, BELOW DECK ONLY.
- F¹ = MINIMUM MODIFICATION FILE SHAFT HOLES OR DASH OPENING.
- F² = MODIFY DASH CAVITY AND/OR PANEL.
- K = INSTALLATION KIT, SPACER OR ADAPTOR REQUIRED.
- K¹ = KIT MODIFICATIONS REQUIRED.
- K² = EXTENSION KIT RECOMMENDED.
- K³ = WHEN EQUIPPED WITH FACTORY "ELECTRONIC" RADIO.
- K⁴ = FABRICATE PANEL/BRACKETS.

- K⁵ = WHEN EQUIPPED WITH STANDARD TWO SHAFT RADIO/TAPE PLAYER. FABRICATE KIT WHEN EQUIPPED WITH FLAT FACE ELECTRONIC RADIO/TAPE PLAYER.
- K⁵ = SCOSCHE KIT RECOMMENDED.
- N = NOT RECOMMENDED. EXTENSIVE MODIFICATION REQUIRED.
- P = PERFECT WITHOUT MODIFICATION.
- P¹ = MODIFY OR REMOVE POCKETS.
- P² = COIN POCKET LOCATION IN-DASH (MAY REQUIRE TRIM KIT).
- P³ = PERFECT WHEN EQUIPPED WITH STANDARD TWO SHAFT RADIO. K WITHOUT.
- U = UNDERDASH.
- W¹ = WITH POWER WINDOWS ONLY.
- W² = WITHOUT POWER WINDOWS ONLY.

NOTE: THIS MANUAL IS BASED ON CAREFULLY DOCUMENTED RESEARCH. ABSOLUTE ACCURACY IS ATTEMPTED BUT NOT GUARANTEED. USE THIS MANUAL AS A REFERENCE GUIDE. SCOSCHE INC. CANNOT BE RESPONSIBLE FOR INCONSISTENCIES THAT MAY OCCUR.

1990-93 LINCOLN MARK VII LSC COUPE



PHOTO 1.

PRELIMINARY: DISCONNECT THE NEGATIVE BATTERY CABLE.

ANTENNA: THE FACTORY POWER ANTENNA IS LOCATED ON THE RIGHT REAR FENDER (STANDARD FORD BASE PLATE).

RADIO REMOVAL AND IN-DASH INSTALLATION:

NOTE: INSTALLATION KIT IS NECESSARY WHEN INSTALLING A SHAFT MOUNT RADIO. WE RECOMMEND A SCOSCHE 1190 KIT.

1. INSERT STANDARD DIN RADIO REMOVAL TOOLS, PULL THE CHASSIS OUT OF THE DASH, DISCONNECT THE ANTENNA AND ELECTRICAL CONNECTORS AND REMOVE THE RADIO. (PHOTO 1)

FRONT DOOR SPEAKER INSTALLATION:

NOTE: FACTORY PROVISIONS ARE FOR 5 1/4" JBL SPEAKERS WITH AN ADAPTOR.

1. CAREFULLY SNAP OFF THE FACTORY SPEAKER GRILLE - BEGIN ALONG THE FRONT PORTION OF THE GRILLE.
2. EXTRACT THE SINGLE SCREW FROM THE DOOR PANEL BRACKET, NEXT TO THE SPEAKER (SEE PHOTO 2).
3. CAREFULLY REMOVE THE PLASTIC TRIM WHICH CREATES A PANEL INSERT AROUND THE WINDOW/DOOR CONTROL PANEL (SEE PHOTO 2).
4. REMOVE THE CARPETED TRIM INSERT FROM THE LOWER SECTION OF THE DOOR, THERE ARE PANEL CLIPS ALONG THE TOP AND SPRING CLIPS ALONG THE BOTTOM.
5. WITH THE TRIM REMOVED LOCATE THE ACCESS HOLE IN THE PANEL, THIS ALLOWS ACCESS TO SINGLE BOLT SECURING THE DOOR RELEASE LEVER (SEE PHOTO 3).
6. CAREFULLY RELEASE THE PANEL FASTENERS AND REMOVE THE PANEL.
7. EXTRACT (4) SCREWS SECURING THE SPEAKER/BACKET, DISCONNECT THE LEADS AND REMOVE THE ASSEMBLY.

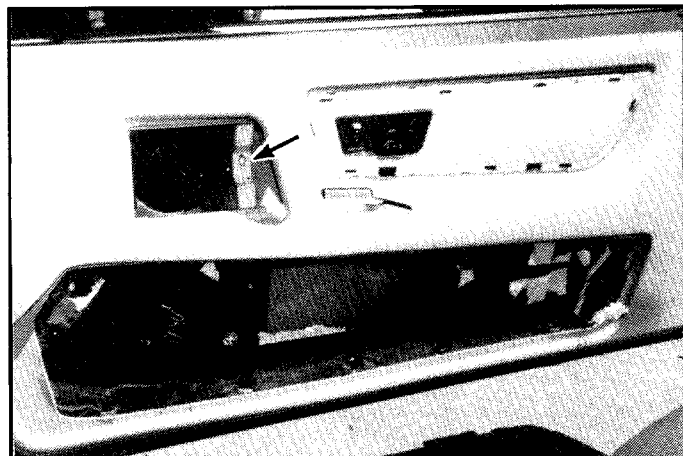

PHOTO 2.

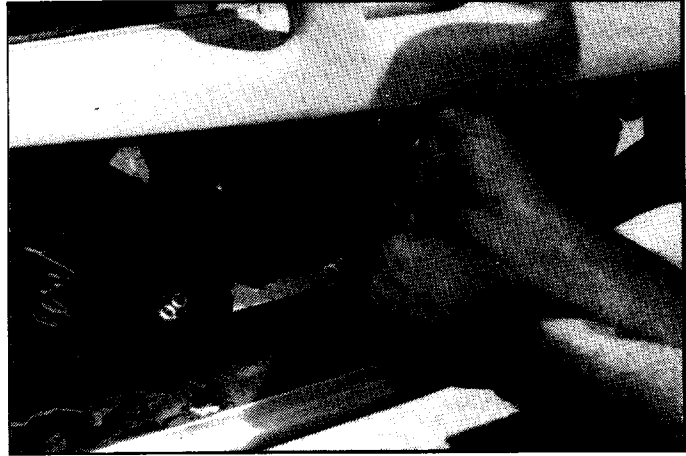
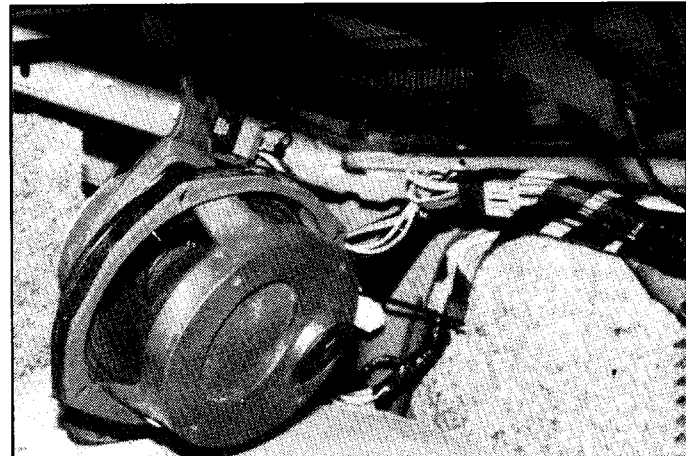

PHOTO 3.

REAR DECK SPEAKER INSTALLATION:

NOTE: FACTORY PROVISIONS ARE FOR 6 x 9" SPEAKERS (3 1/2" TWEETER SATELLITE INCLUDED).

1. UNCLIP THE RUBBER STRAP SECURING THE SPEAKER, DISCONNECT THE LEADS AND REMOVE THE SPEAKER.



REAR SPEAKER ASSEMBLY.